



Grorich External Venetian Blinds

Contents

1. Profiles
2. Structure
3. Technical Data
4. Standard Color
5. Installation
6. Motor And Control
7. Project Cases

Profiles

Grorich External venetian blinds is designed for external sun shading, windproof and UV-proof.

Feature :

1. Façade use
2. sunshading, sunlight angle adjust and protect personal privacy.
3. The system could run up and down, ensure day lighting, ventilation and visual field.
4. The system use side track guidance, which could ensure a longer service life and performance
5. Over 6 kind of tests on Anti-corrosion, Anti-aging, wind loading, waterproof, Abrasion resistance and UV-resistance



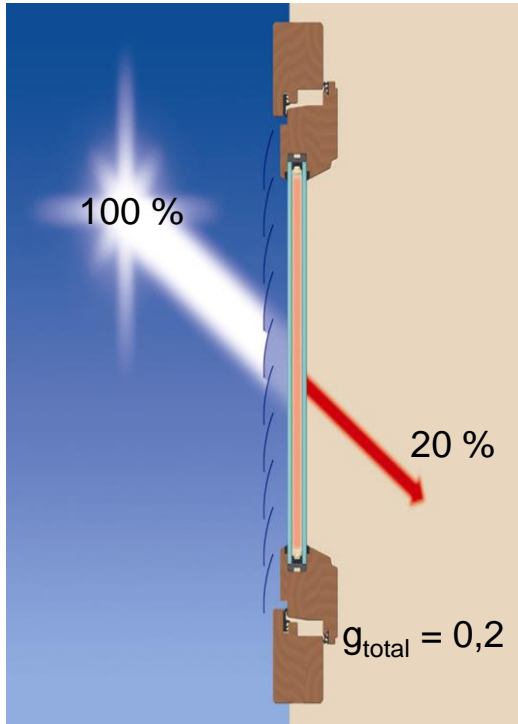

After external venetian blinds installation, over 80% heat be blocked outside.

BEST

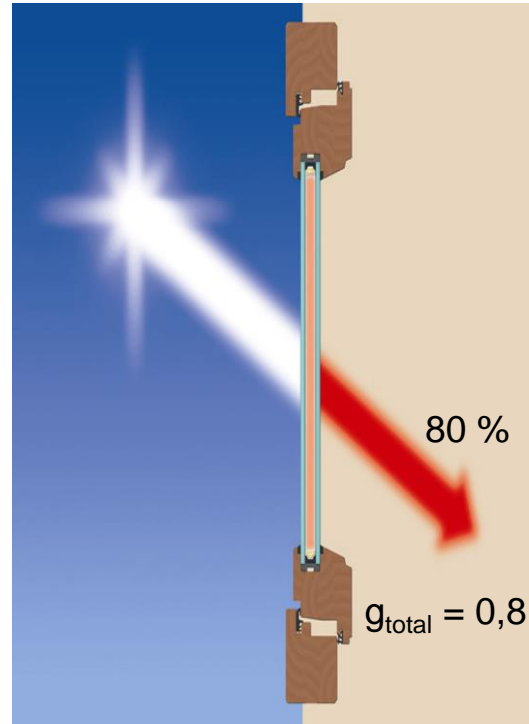

Without external venetian blinds, over 80% heat could through the glass

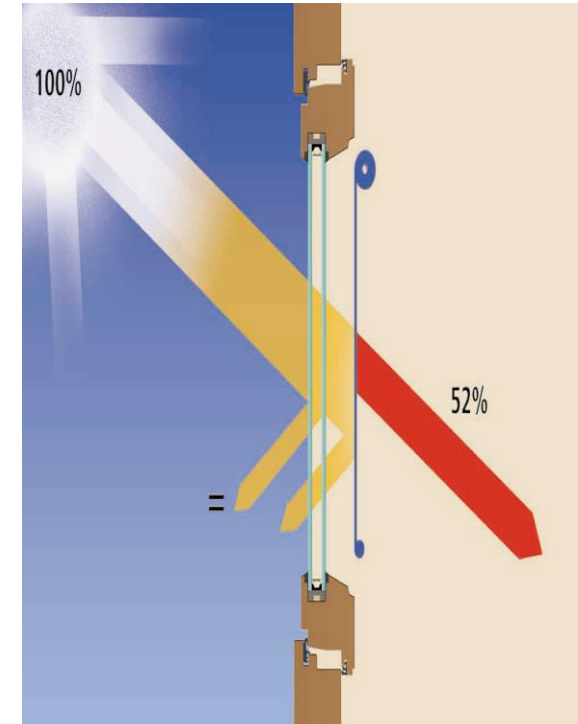

After installing indoor sun shading screen, 52% heat still could inside the room

Structure

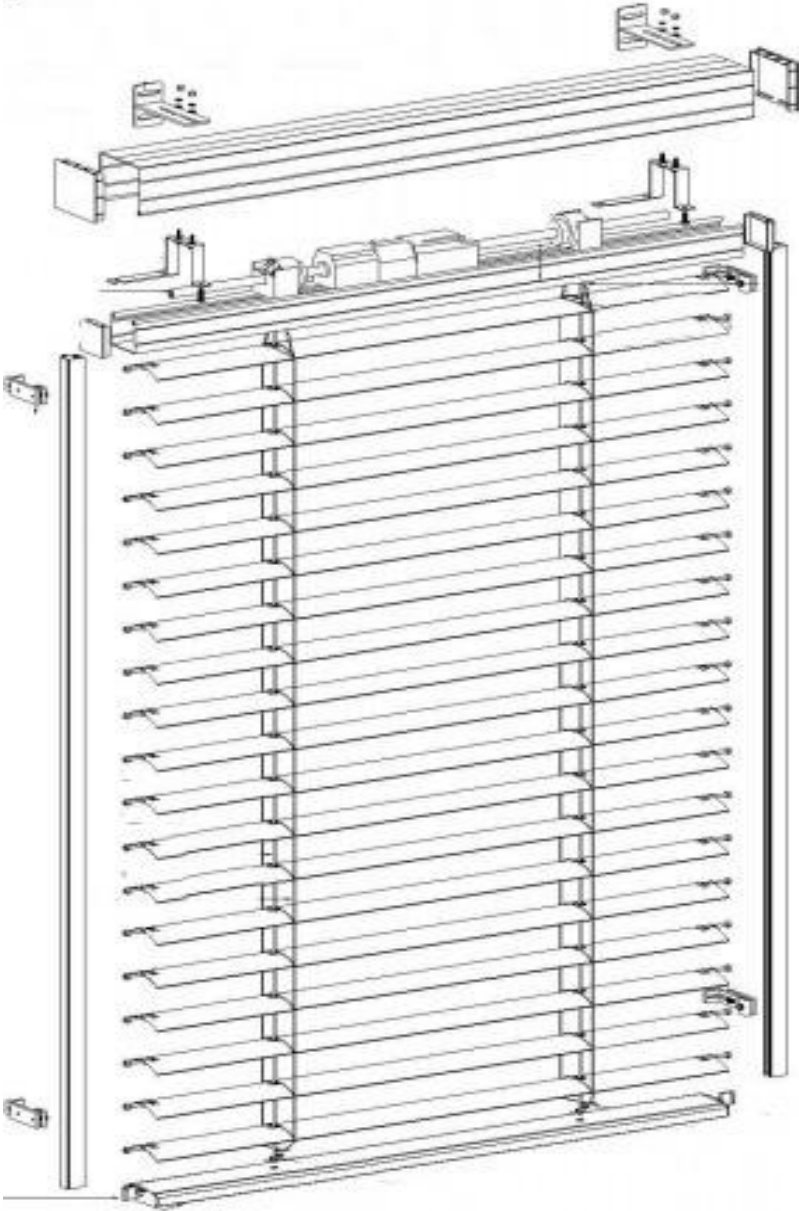

Side track
and control
system

Technical data



C80



CR80



C60



C50

0.7-3

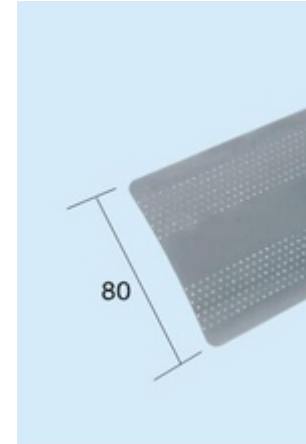

Surface pinholes design could be provided

Blade material is aluminum 6063, strong enough for external use and windproof.

1. Service life: 10years
2. Windproof : 8degree
3. Blade size : width 80mm Thickness 0.45mm, Weight95-110g/m
4. Example weight : 4KG (H1000mm*W1000mm)
5. Turning degree : 0-90°
6. Surface treatment: Enamel paint
7. Lift belt: Swiss import, polyester, anti-UV and weather proof. Service life over 100 thousand times,
8. Produce :

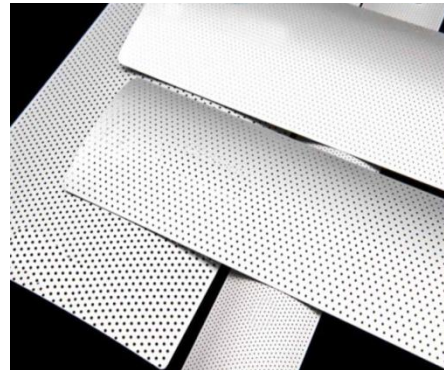

Technique Data

H	hs	tn
1500	210	120
2000	240	120
2500	270	120
3000	300	120
3500	330	120
4000	360	120
4250	380	120
h Height of bind		
hs	Height of the cover profile	
tn:	Distance between cover and window	
w:	Width of blind	
$hs = h \times 0.06 + 120mm$		

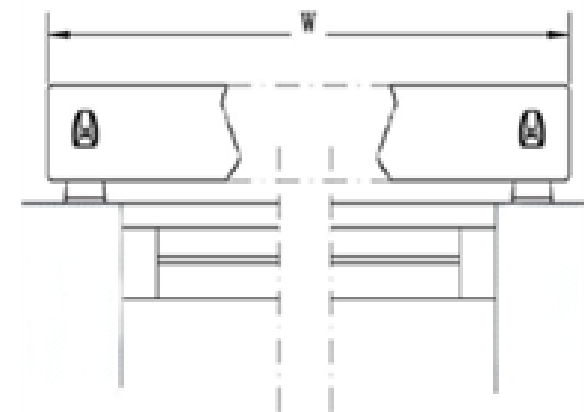
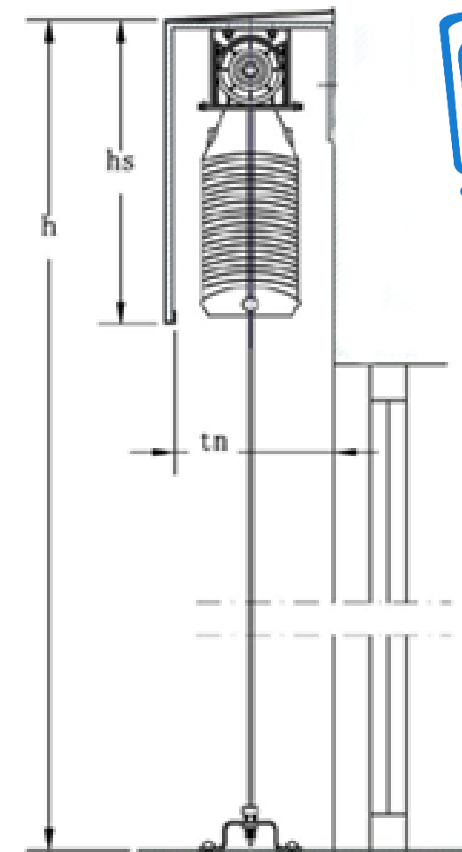

product Size	Manual	Motorize
Minimum Width	600mm	600mm
Maximum Width	4500mm	5000mm
Minimum Height	800mm	800mm
Maximum Height	4500mm	5500mm
Maximum Area	8 m ²	12 m ²

Standard Color



White



Dark Grey

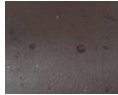

Brown



Silver

Installation

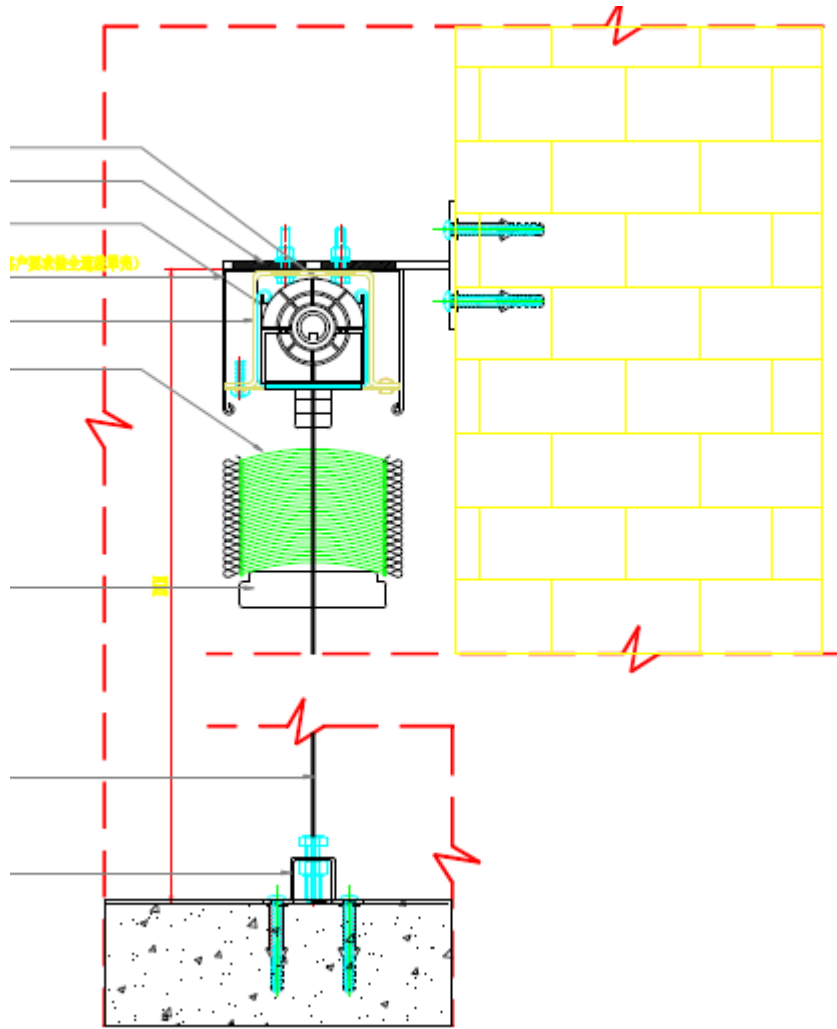

Out Mount

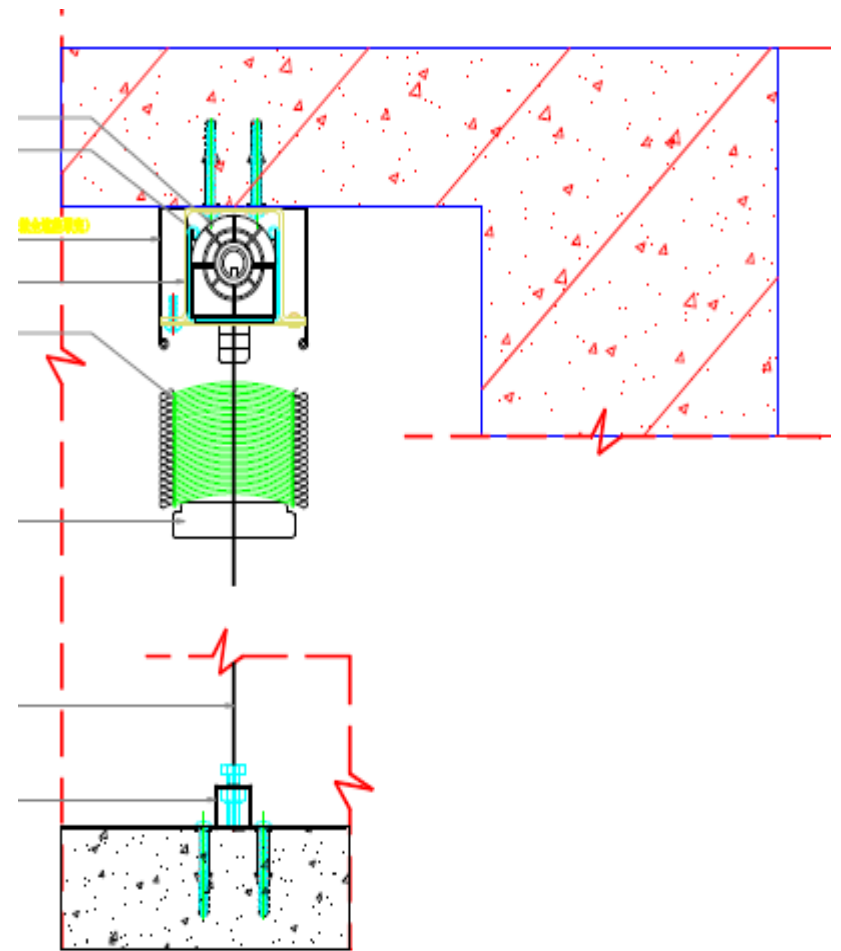

Inner Mount

Motor and Control system



Specialized Motor for external venetian blind

Data :

1. 6N/10N
2. 135W
3. AC220V
4. 0.45A
5. IP54



Remoter



Switch



Weather sensor
(Optional)



Smart home system
(Optional)

Project Cases

















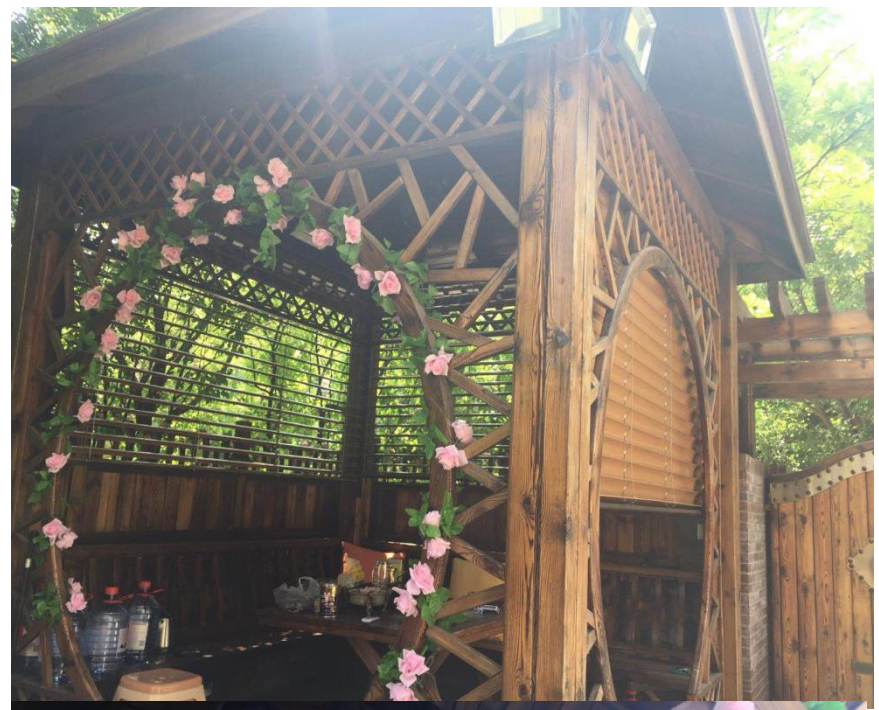





GRORICH HORIVERT PVT. LTD.

Symphony of Shades

Address : #49/2, Muthurayaswamy layout,
Srigandharakaval, Sunkadakatte, Magadi Road, Bangalore -
560 091. India

Phone: +91 9845043292/ +91 9980043292

Email: info@grorichhorivert.com

www.grorich.in